



**International Twelve  
Metre Class Rule  
2011**

**Copyright ISAF / ITMA**

# 12

## INTERNATIONAL TWELVE METRE CLASS RULE

17<sup>th</sup> July 2011

### CONTENTS

RULE NO	RULE	PAGE
	<b>PREAMBLE</b>	1
	<b>SECTION A - GENERAL</b>	1
1	Language	1
2	Interpretation	2
3	Amendments (spare)	2
	<b>SECTION B - RATING FORMULA</b>	3
5	Rating	3
6	Length	3
7	Mid-Ship Girth Difference	4
8	Freeboard	4
9	Sail Area	5
10	Propeller Allowance	5
	<b>SECTION C - LIMITATIONS AND PENALTIES</b>	6
11	Draft	6
12	Displacement	6
13	Beam	7
14	Tumble Home (see also Appendix "C")	7
15	Sheerline	7
16	Hollows (see also Appendix "D")	7
17	(spare)	8
	<b>SECTION D – CONSTRUCTION</b>	8
18	Hull	8
19	Appendages (including rudders, trim tabs and keel wings)	11
20	Keel and Other Ballast	12
21	Deck	12
22	Cockpits (see also Appendix "C")	12
23	Hatches and Companionways	13
24	Minor Openings	14

25	Winch Placement	14
26	(spare)	15
	<b>SECTION E – RIG</b>	<b>15</b>
27	Mast	15
28	Boom	16
29	Spinnaker Pole	17
30	Standing Rigging	17
31	(spare)	17
	<b>SECTION F - SAILS</b>	<b>17</b>
32	Sails – General	17
33	Rated Sail Area	18
34	Mainsail	19
35	Genoa and Staysail	19
36	Spinnaker	20
37	Gennaker	20
38	(spare)	20
	<b>SECTION G - OTHER RULES</b>	<b>21</b>
39	Running Rigging, Fittings and Other Equipment	21
40	Crew	21
41	(spare)	21
	<b>SECTION H - ADMINISTRATION</b>	<b>21</b>
42	Application and Compliance	21
43	Measurement Certificate	22
44	Measurers	23
45	Plan Approval and Post Construction Inspection	24
46	Measurement – General	27
47	Measurement Marks (see also Appendix "B")	27
48	Measurement Afloat	27
	<b>APPENDICES</b>	<b>30</b>
A	Measurement Certificate (class rules 43)	30
B	Measurement Marks (class rule 47)	35
C	Tumble Home (class rule 14) and Cockpits (class rule 22).	37
D	Hollows (class rule 16)	38
E	"Age Allowance" Appendix	39

## **PREAMBLE**

This Rule was approved by the ISAF and is effective from 17<sup>th</sup> July 2011. It replaces all previous editions.

This revised rule, particularly those sections relating to construction and survey, is intended for yachts which are raced inshore "around the buoys" with tenders or assistance present, as opposed to offshore in dangerous wind and sea conditions with or without tenders.

A large number of Twelve Metre Yachts have been built over a period of some ninety years. In the late 1990's there was considerable renewed interest in the racing of Twelve Metre Class yachts of differing periods.

This version of the Rule, while retaining the "state of the art" nature of the Twelve Metre Rule, has added appendices which address disparities in design and performance which will re-enfranchise Twelve Metre Class yachts which may not be able or willing to comply with the current "state of the art" part of the Rule.

## **SECTION A - GENERAL**

### **1 LANGUAGE**

1.1 The official language of the International Twelve Metre Class Rule is English. In questions of translation, the English text shall prevail.

1.2 Unless otherwise prescribed, the word or words:

- (a) "bottom" means the area below a line 180mm above the yacht's measurement waterline.
- (b) "class rule" means the International Twelve Metre Class Rule.
- (c) "deck" means the upper surface of the hull inside the sheerline including cockpits, recesses, etc., and the transom.
- (d) "GRP" means glass reinforced plastic.
- (e) "hull" means the canoe body, deck and keel, but not rudders or trim tabs.
- (f) "ITMA" means the International Twelve Metre Association.
- (g) ISAF means the International Sailing Federation .
- (h) "keel" means the external ballast package below and attached to the keel plate.

- (i) "lead" means lead or lead alloys of specific gravity not greater than pure lead (11.40).
- (j) "measurement committee" means the measurement committee at a regatta in which the yacht is entered.
- (k) "owner" means the owner, the owner's representative and, while racing, the skipper.
- (l) "racing rules" means The Racing Rules of Sailing .
- (m) "topsides" means the area of the hull above a line 180mm above the yacht's measurement waterline and below the sheerline as defined in rule 15.

1.3 The word "shall" is mandatory; the word "may" is permissive.

## 2 INTERPRETATION

2.1 Interpretations of the class rule may be sought and shall be issued in a timely manner as follows:

- (a) Questions of interpretation shall be submitted in writing to the ITMA Technical Director.
- (b) The ITMA Technical Director shall consult with ITMA Technical Committee.
- (c) As soon as possible, the ITMA Technical Director shall issue a public interpretation in writing to the individual seeking the interpretation, all ITMA members, and the Technical Department of ISAF.
- (d) Each two years all interpretations shall be reviewed by the ITMA Technical Committee and the ITMA Secretariat. If the deemed appropriate the interpretation shall be submitted to ISAF to become amendments of the class rules accordance with class rule 3.

2.2 If a measurer is in doubt as to the application or interpretation of the class rule, he shall seek an interpretation in accordance with class rule 2.1. The measurement shall be deemed incomplete until this has been done.

## 3 AMENDMENTS

Amendments may be made by the ISAF upon the recommendation of ITMA.

4. (SPARE NO.)

**SECTION B - INTERNATIONAL FORMULA****5 RATING**

The rating, in metres, is given by the formula:

$$\text{Rating} = \frac{L + 2d - F + \sqrt{S}}{2.37}$$

where:

L	=	length (metres)
d	=	girth difference (metres)
F	=	freeboard (metres)
S	=	sail area (square metres).

**6 LENGTH**

6.1 The length "L" in the rating formula shall be the sum of:

- (a) length measured at a height of 1.5% of the class rating (180mm) above the waterline LWL measured between the inner edges of the L1 marks; and
- (b) one and one-half times the difference between the chain girth at the forward end of this length measured to points 5% of the class rating (600mm) above "L" and twice the vertical height from "L" to those points (1.2m); and
- (c) one-third of the difference between the chain girth, from sheerline to sheerline, at the aft end of this length (the stern section), and twice the vertical height at the side of the yacht at this section.

6.2 For the purpose of calculating the rating, the girth difference at the bow section as defined above shall not be taken as less than 3% of the class rating (360mm); the girth difference at the stern section shall not be taken as less than 10% of the class rating (1.2m).

6.3 The afterbody of the yacht will be so shaped that an aft chain girth can be taken at the section intersecting the aft overhang at a height of 3% of the class rating (360mm) above the LWL (L2).

6.4 If the girth difference at the L2 section, ie., the chain girth from sheerline to sheerline (or the intersection of the sides of the yacht with the transom) less twice the vertical height is less than 65% of the stern-girth difference at L1, one third of the deficiency shall be added to the stern girth difference in calculating the yacht's rating. The horizontal distance from L1 to L2 shall not be less than 0.380m.

- 6.5 The girth at each section shall be the shortest chain girth (ie., the "great circle" distance along the surface of the hull) between the measurement points, O, or sheerline through the outer edge of the length mark L1 or L2.
- 6.6 The hull including the rudder(s) at or below 150mm below the waterline plane shall not exceed the measured length L1L1.
- 6.7 The waterline length shall be the length measured between the forwardmost of :
- (a) the forward "L" mark (subject to any "bridging" which may be required under class rule 16.2) or the forwardmost part of the forward rudder (if any);
- and the aftermost of:
- (b) the aftermost part of the hull at or below the LWL, including any fairing strips attached to the hull, but excluding the rudder and normal rudder hangings; or the axis of the rudder stock.

## 7 MID-SHIP GIRTH DIFFERENCE

- 7.1 The girth difference "d" in the rating formula shall be the sum of the differences between the skin girth and chain girth on the port and starboard sides of the yacht measured at the vertical section 0.55 LWL from the forward end of the LWL measured from the sheerline to points on the surface of the hull 12.5% of the class rating (1.5m) below the waterline.
- 7.2 The skin girth is the measurement along the surface of the hull from the sheerline, through the upper "d" mark, and the "I" mark to the centre of the lower "d" mark "d1." The chain girth is the measurement between the same points with the measuring tape pulled taut.
- 7.3 The yacht shall be so designed that it is possible to place the lower "d1" marks on the surface of the hull and to measure a continuous skin girth at the station. The radius of the hull, measured in any horizontal plane parallel to the waterline plane at or above the lower "d1" mark, shall not be less than 1.8m.

## 8 FREEBOARD

- 8.1 The freeboard "F" in the rating formula shall be the lesser of :
- (a) 1.210m, or
  - (b) one half of the sum of the mean freeboards at the mid-ship girth station, at the bow L1, and at the stern L1; minus 600mm.

Freeboard shall be measured to the sheerline (see class rule 15).

- 8.2 When calculating the rating, the freeboard aft shall not be taken as more than 0.825 of the freeboard forward. The actual freeboard forward shall not be less than 1.2 times the freeboard amidships, but for calculating the rating shall not be taken as more than 1.5 times the freeboard amidships.

9 SAIL AREA

- 9.1 Sail area "S" in the rating formula shall be the sum of the rated area of the mainsail and the rated area of the foretriangle (see class rule 33).

10. PROPELLER ALLOWANCE

If a yacht is fitted with an engine and propeller which conform in every way to the conditions prescribed below while racing, the sail area calculated in Rule 9 above shall be multiplied by the following factor prior to use in the rating formula in Rule 5. If an engine and propeller are not fitted or the engine/propeller installation does not comply with all the following criteria, the propeller factor shall be 1.000.

Centreline of strut or shaft drive where the plane of propeller shaft or strut is not skewed relative to the yacht centreline (skew defined below)

$$\text{Propeller factor} = 0.985$$

Skew is defined as the angle between the propeller shaft run and the hull, calculated as:

Offset = the distance from the geometric centre of the propeller hub to the nearest point on the hull.

Shaft length = the length of the shaft from its exit at the hull to the geometric centre of the propeller hub.

Skew Angle = the inverse-sine of Offset divided by Shaft Length.

If skew is less than 20 degrees – Propeller Factor = 0.985

If skew is greater than 20 degrees – Propeller Factor = 0.975

This factor shall be applied as follows:

$S(\text{for use in the Rule 5 Rating Formula}) = S(\text{from Rule 9}) \times \text{Propeller factor.}$

To qualify for this correction all the following conditions shall be observed.

- (a) The yacht shall be able to achieve a speed of 7 knots under power with bare poles in still conditions.

- (b) The propeller diameter shall exceed 400mm and may be solid, folding or feathering. (No additional allowance is to be made for solid propellers.)
- (c) The propeller, shafting, aperture, or strut drive shall be exposed to the water flow whilst racing and shall not be fitted with covers or fairing strips.
- (d) The engine, shafting, and propeller must be permanently installed.
- (e) If the propeller is fitted to an exposed shaft the shaft shall be circular and at least 28 mm in diameter. Any exposed shaft strut shall have a minimum chord length of 100mm for at least 75% of its span and a thickness of not less than 20 mm. The strut boss shall be at least 55 mm in diameter at any point and a length of not less than 100 mm.
- (f) If the propeller is fitted in an aperture the clearance from the aperture to a propeller blade in any position shall not be less than 50mm.
- (g) If the propeller is fitted to a strut drive the strut chord length at 1/3 of the span from the hull to the centreline of the propeller shall be greater than 170 mm. The minimum thickness of the strut at any point shall not be less than 40mm.  
The boss diameter of the strut drive shall exceed 95 mm and the boss length shall exceed 170 mm.

## **SECTION C – LIMITATIONS AND PENALTIES**

### 11 DRAFT

- 11.1 The maximum draft allowed without penalty shall be  $0.16 \times (\text{LWL}) + 500\text{mm}$ .
- 11.2 If the draft exceeds that allowed in class rule 11.1, three times the excess shall be added to the rating.
- 11.3 The draft shall be taken as the vertical distance below the LWL plane (with the yacht level fore and aft and athwartships) to the lowest point of the hull or appendage in any position.

### 12 DISPLACEMENT

- 12.1 The displacement of the yacht in cubic metres shall not be less than  $(0.2 \text{ LWL} + 0.15)^3$  without penalty.
- 12.2 If a yacht has a displacement less than that required by class rule 12.1, the difference between the length on LWL to which her actual

displacement corresponds and her actual waterline length shall be doubled and added to the length measurement "L" in the rating formula.

13 BEAM

13.1 The beam, measured at the point of greatest beam in the plane one-third of the freeboard at the mid-ship girth station above the waterline plane, shall not be less than 3.6m. Any deficiency shall be multiplied by 4 and added to the length measurement "L" in the rating formula.

13.2 The beam of the hull, including any appendage, measured at any point below 1.7m below the LWL shall not exceed 3.6m.

14 TUMBLEHOME (See also Appendix "C")

14.1 The tumble home on each side of the yacht shall not exceed 2% of the extreme beam without penalty.

14.2 When the tumble home exceeds the amount allowed in class rule 14.1, three times the excess shall be added to the rating.

15 SHEER AND SHEERLINE

15.1 The sheer of the yacht between the point 75mm aft of the foremost point of the hull and the stern L1 section shall be a fair continuous concave curve.

15.2 If the hull-deck joint has a radius not exceeding 75mm, the sheerline, for measurement purposes, shall be taken as the intersection of the extensions of the lines of the deck and the hull.

15.3 If the hull-deck joint has a radius exceeding 75mm, the sheerline shall be taken as the further outboard of:

(a) the inboard edge of the radius; or

(b) the limit of the tumble home.

16 HOLLOWES (See also Appendix "D")

16.1 There shall be no hollows in the surface of the hull between the LWL plane and the sheerline except as follows:

(a) at the stern within the buttock line 460mm from the yacht's centreline and below L1 (180mm above the LWL);

(b) hollows which do not occur at measurement points and which do not exceed 1.0 mm in depth in a length of 1.0 m, or 3mm in any length.

16.2 If there is an irregular hollow in the stem of the yacht within a vertical distance of 150mm above or below the LWL plane, it shall be bridged within the limits of that vertical distance for the purpose of determining the waterline length. For the purpose of this rule, a hollow shall be considered to be irregular if :

- (a) a hollow starts and finishes within 150mm above and 150mm below the LWL; or
- (b) the radius of the concave curve is less than 75mm; or
- (c) the hollow is caused by the intersection of straight lines or convex curves; or
- (d) any part of the stem within 150mm of the LWL is forward of the stem above it.

A hollow in the stem shall not affect the placing of the length mark "L". See Appendix D

17 (SPARE NO.)

## **SECTION D - CONSTRUCTION**

18 HULL

18.1 Compliance with the following requirements does not necessarily ensure that a yacht is of adequate structural strength. The structural strength of the yacht is the responsibility of the owner and his designers, builders and crew, and not ISAF or ITMA.

18.2 The hull, excluding keel, shall be constructed according to plans found to comply with the minimum weight distribution by the ITMA Technical Director or ITMA nominee. The ITMA Technical Director or ITMA nominee shall only approve plans such that the hull, excluding keel, is neither of less weight nor more beneficial weight distribution than given below.

18.3 The total structural weight in the various zones of the hull given below shall be such that the average weight per square metre of external hull surface area are not less than the following:

(a) Bottom (measured from the forward end of the measured length L1L1):

Zone 1	0% to 25% L1L1	25.0 kg/square metre
Zone 2	25% to 75% L1L1	31.0 kg/square metre

- |     |   |                  |                      |
|-----|---|------------------|----------------------|
|     | Zone 3                                  | 75% to 100% L1L1 | 25.0 kg/square metre |
| (b) | Topsides                                |                  | 18.0 kg/square metre |
|     | Additional for 1m length in way of mast |                  | 9.0 kg/square metre  |
| (c) | Deck                                    |                  | 17.0 kg/square metre |
|     | Additional for 1m length in way of mast |                  | 9.0 kg/square metre  |
- 18.4 Nowhere shall the topsides or bottom shell plating, laminates or planking be less than 12.0 kg/square metre.
- 18.5 The average weight distribution requirements above shall include, in addition to hull shell, all normal hull structure such as frames, floors, beams, web frames, longitudinals, girders, knees, brackets and centreline structure. It shall not include local structural items or structural reinforcement for fittings such as chainplates, forestay fittings and structure, mast step, mast partners and control structure and runner sheave boxes.
- 18.6 The amidships block increase in required weight distribution for the bottom may be faired into the required end distribution, but the total area in the amidships area shall be maintained. See Figure I. Correspondingly, the same approach may be taken in the topsides and deck for the required weight distribution increase in way of the mast.
- 18.7 If this non-rectangular distribution is used in the bottom amidships area, then the distribution shall be constant between a point 500mm forward of the mast and a point 500mm aft of the aft most point of attachment of the keel to the hull. See Figure I.
- 18.8 In no case is the weight per unit area in the amidships bottom region to reduce below the average weight per unit area of 25 kg/square metre.
- 18.9 If the non-rectangular distribution is used for the required increase in the topsides and the deck in way of the mast, it shall extend at least 300mm forward of the forwardmost position of the front side of the mast to 300mm aft of the aftmost position of the aft side of the mast respectively.

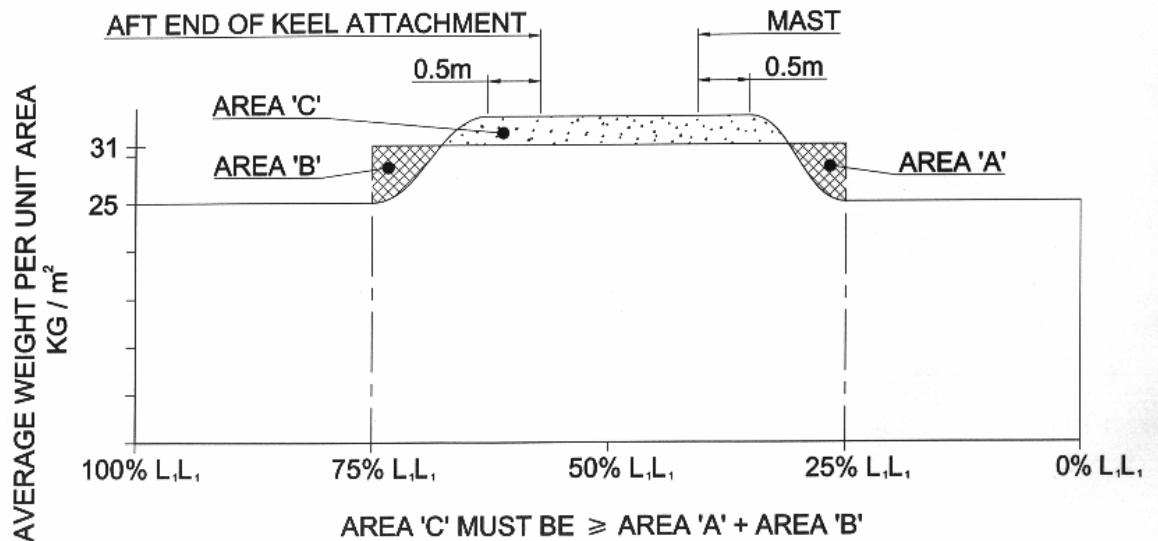

**BOTTOM WEIGHT DISTRIBUTION DIAGRAM**

FIGURE 1

- 18.10 Where framing is used to achieve the required weight per unit area, the area used to assess the unit weight shall be a vertical band bounded by one half of the major transverse or web frame spacing each side of that major frame or web respectively, and the girth length at that position. In the case of no framing; the limits of the panel shall be the bow, 25% L1L1, 75% of L1L1, and the stern.
- 18.11 Where, in the bottom zone, a frame bay falls across a vertical zone boundary (ie., 25% L1L1 or 75% L1L1), the required weight distribution shall comply with the requirements each side of the zone boundary.
- 18.12 There shall be no negative tolerance on the overall weight distribution of the yacht. However, minor (maximum 5%) local negative departures from the requirements will be permitted in each of the three horizontal zones (ie., bottom, topsides and deck) in the bow to 25% L1L1 and the 75% L1L1 to stern regions, provided the weights and moments of these regions are not less than the weight and moments of the constant weight per unit area of these regions when moments are taken about the 25% L1L1 and 75% L1L1 points respectively.
- 18.13 The hull, excluding keel, shall be made only from the following materials or their combinations, except for fastenings which may be of any material:
- aluminum alloy--5000 and 6000 series alloys with a specific gravity greater than 2.65;
  - GRP--E, R, S and S2 glass polyester, vinyl ester or epoxy resins and sandwich cores of any commercially available type;

- (c) wood--any species with any alloy of steel, aluminium, copper or nickel for floors, knees, etc.
- 18.14 For GRP yachts, the internal surface of the hull shall incorporate a lightweight layer of woven reinforcement containing a coloured tracer roving or thread at centres not exceeding 300mm.
- 18.15 Free flooding compartments (ie., compartments or containers that hold liquid such that they may increase performance of the yacht) are prohibited.
- 18.16 A patented design relating to hull configuration is permitted provided the design is available for free use by the owner of any other International Twelve Metre yacht.

To enable determination of displacement by weighing, yachts shall be constructed with lifting eyes to enable the yacht to be lifted and weighed from a single point no higher than 2 metres above the deck. This requirement shall only apply to yachts built after 1970.

- 19 APPENDAGES (including rudders, trim tabs and keel wings)
- 19.1 Rudders and trim tabs shall be constructed only of the following structural materials: wood, aluminium alloy, GRP, carbon fibre and/or Kevlar(TM) reinforced plastic, stainless steel or steel. Titanium may be used for the rudder stock and hangings; lead for the trim tab. Any commercially available core material may be used.
- 19.2 No part of a rudder which extends aft of the aft end of the LWL or forward of the forward end of the LWL shall exceed 190mm in thickness.

The total number of movable surfaces shall not exceed two.

- 19.3 A fairing strip shall not constitute a movable appendage provided that:
  - (a) it is not controllable,
  - (b) it is flexible,
  - (c) it provides fairing only onto the movable appendage, and
  - (d) its chord length is less than 200mm or its spanwise length of contact with the movable appendage is less than 10% of the span of the movable appendage.
- 19.4 Appendages shall not be retractable.

- 19.5 Appendages may be adjusted in rotation about a single axis only, provided that racing rules 51 (Shifting Ballast) and 42 (Means of Propulsion) are not infringed.
- 20 KEEL AND OTHER BALLAST
- 20.1 The keel and other ballast shall be constructed of material of specific gravity not greater than lead.
- 20.2 Moveable keels are not permitted.
- 20.3 Centreboards and similar contrivances are prohibited.
- 21 DECK
- 21.1 The deck shall not have negative camber, ie., over the deck beams it shall not fall below a straight line from the sheerline on one side of the yacht to the sheerline on the other.
- 21.2 Recesses in the deck appropriate in size to accommodate items of gear and equipment are permitted as follows:
- (a) a trough to accommodate the spinnaker pole provided it is not wider than 550mm or deeper than 200mm (measured from the immediately adjacent deck), and provided it does not extend further aft than the forward side of the mast.
  - (b) a recess to accommodate the forestay attachment and jib tack fitting provided that it does not extend further aft than 300mm from the forward end of the J measurement. This recess may be continuous with the trough for the spinnaker pole;
  - (c) fittings including winch bases may be in reasonably watertight recesses in the deck except that winch drums shall be above the level of the deck or in cockpits.
  - (d) recesses for fittings may drain into the hull through small holes. See also class rule 24.
- 22 COCKPITS (See also Appendix "C")
- 22.1 Except as otherwise permitted below, cockpits may be positioned anywhere aft of the mast.
- 22.2 The total area of cockpits shall not be less than 4.6 square metres nor more than 10.0 square metres.
- 22.3 Recesses permitted in class rule 21.2 shall not be included in any calculation of the cockpit area, provided the total area of such recesses

excluding the spinnaker pole trough does not exceed 1.5 square metres.

- 22.4 Forward of a line drawn athwartships 3.0m aft of the mid-ship girth station, the distance from the edge of a cockpit to the sheerline shall not be less than 760mm. Aft of this line the corresponding minimum distance shall be 380mm.
- 22.5 Except for small recesses to accommodate the lower parts of the yacht's steering wheels, the cockpit sole shall nowhere be lower than 380mm above the LWL plane.
- 22.6 A cockpit may extend under the side deck provided no part of the cockpit side within a vertical distance of 150mm from the cockpit sole is below 30 degrees to the horizontal measured as shown in Appendix "C". No part of a cockpit shall be less than 380mm from the sheerline viewed in plan.
- 22.7 Each cockpit shall be able to drain overboard by not less than two scuppers the total area of which is not less than 20 square centimetres. The total area of scuppers in all cockpits shall not be less than 50 square centimetres.
- 22.8 Self-bailers are permitted but shall not be included in the calculation of the area of the cockpit scuppers.
- 22.9 Each cockpit shall be watertight except for cockpit drains and small openings permitted under class rule 24, and for openings, each not to exceed 0.1 square metres in area, which are closed by screw or hinged covers and which are not lighter than the structure they replace.
- 22.10 Fixed clear panels in the side of a cockpit are permitted provided they are not lighter than the structure they replace.
- 22.11 A radius between the deck and cockpit side not exceeding 75mm shall not be included in the calculation of cockpit area.

## 23 HATCHES AND COMPANIONWAYS

- 23.1 There shall be not more than two hatch openings in the deck forward, and not more than four hatches or companionways aft of the mast.
- 23.2 The minimum distance from a hatch opening to the sheerline shall not be less than 500mm.
- 23.3 The total area of the hatches forward of the mast shall not exceed 1.2 square metres. Each hatch shall be closed by a cover attached to the deck by hinges, slides or similar arrangement.

- 23.4 The area of each hatch opening aft of the mast shall not exceed 0.6 square metres. A hatch cover is not required when such a hatch:
- (a) does not provide access to the inside of the hull; and
  - (b) when the space below to which it does give access:
    - (i) is reasonably watertight;
    - (ii) has a volume which does not exceed 1.5 cubic metres; and
    - (iii) has drains overboard.

If these requirements are not met, there shall be a reasonably watertight cover attached to the deck or cockpit side by hinges or slides.

- 23.5 All hatch and companionway covers shall be not lighter than the structure they replace.
- 23.6 A companionway opening out of the side of a cockpit shall be fitted with a sill having a height of not less than 220mm above the cockpit sole. Companionways shall be provided with secure hatch covers and shutters which are substantially watertight up to the level of the deck when closed. The area of such a companionway shall be taken as the area of the opening in the deck.
- 23.7 Yachts which have their hatches and companionways modified to comply and continue to comply with the Offshore Racing Council Category 1 Regulations shall be exempt from all the Rule 23 requirements above.

## 24 MINOR OPENINGS

- 24.1 Small openings or holes in the deck, or in the sides of cockpits and which are above 220mm above the cockpit sole for passing rigging, lanyards or similar lines and attachments are permitted.
- 24.2 If the area of an opening or hole permitted in class rule 24.1 exceeds 40 square centimetres, a gaiter boot or other means of closing the opening shall be provided.

## 25 WINCH PLACEMENT

- 25.1 All winches other than halyard winches shall be mounted on or above deck or in a cockpit. They shall be so located as to be operated and tailed only from either the deck or a cockpit.

- 25.2 Headsail sheet winches shall not be placed so as to require a crewmember to operate or tail such winches from a position in the area bounded by a line drawn to contain the winch, the turning block, the deck edge and the shroud.
- 26 (SPARE NO.)

## **SECTION E - RIG**

### 27 MAST

- 27.1 The mast shall be constructed of wood, aluminium alloy, glass reinforced plastic, or any combination thereof. Thin plastic (polyethylene or similar) strips to form internal compartments to separate halyards, etc., are permitted.
- 27.2 The mast, including the luff groove or track, and any stiffening, shall comply with the following dimensions:

Location	Athwartships minimum (mm)	Fore/aft maximum (mm)	Section Area* Minimum (sq. cm)
At upper measurement band	121	194	143
At band top of "I"	194	292	366
At half height of "I"	243	358	572
At 180mm above the sheerline	243	358	572

\*The section area is the area of the mast forward of the transverse line through the forward edge of the luff groove or track.

If the spinnaker pole track is integral with the mast tube it shall be included in the above maximum fore and aft dimensions. If the track is external to the mast tube it shall be considered a fitting and shall be no longer than necessary to set, fly and gybe the pole

- 27.3 Between the measurement points, the profile of the mast shall be a fair and continuous convex curve.
- 27.4 The weight of the mast, including all fittings, spreaders, hydraulic pipes and rams (but not mast jack, if any) and heel plug, but excluding standing and running rigging shall not be less than 454kg. The centre of gravity shall not be less than 9.5m (0.38 of the rule height of the mast) above a point 180mm above the sheerline.
- 27.5 Corrector weights may be inserted in the mast to bring it up to the minimum permitted weight or to correct the position of the centre of gravity.

- 27.6 No devices shall be fitted or employed to move the athwartships position of the mast at its heel or at the deck. The clearance on each side of the mast at the mast partners shall not exceed 20mm.
- 27.7 Permanently bent, deck stepped, and rotating masts, and masts hinged anywhere except at the heel are prohibited. For the purpose of this rule, with aluminium masts a permanent set not exceeding 150mm between the upper and lower measurement bands is permitted.
- 27.8 Measurement bands, not less than 20mm wide, shall be marked on the mast so that they are clearly discernible when racing as follows:
- (a) Lower band, the upper edge of which shall not be more than 1.550m and not less than 1.220m above 180mm above the sheerline; and
  - (b) Upper band, the lower edge of which shall not be more than 2 5.0m above 180mm above the sheerline.
- 27.9 When the boom is horizontal and at its lowest position on the mast, the line of the top of the boom, when extended, shall not be below the upper edge of the lower measurement band.
- 27.10 The highest point of the mainsail headboard and/or the headboard carriage on the mast shall not extend above the lower edge of the upper measurement band.
- 27.11 The luff groove or track on the mast shall be fixed and not move side to side on the mast section.
- 28 BOOM
- 28.1 The boom shall be made of wood, aluminium alloy, GRP, Kevlar(TM) and/or carbon fibre reinforced plastic or any combination thereof.
- 28.2 The boom, including the sail groove or track but excluding other fittings, shall not exceed 350mm in depth. No part of the boom shall exceed 220mm in width. The boom shall not be less than 135mm in width, except in way of the gooseneck or clew fittings. Struts and outriggers are prohibited.
- 28.3 A permanently bent boom is prohibited. For the purpose of this rule, with aluminium booms a permanent set not exceeding 50mm over the length of the boom is permitted.
- 28.4 Regardless of the means the mainsail foot is tensioned, a stop shall be fitted to prevent the clew of the mainsail from extending beyond the maximum permitted value of "B". Accordingly, a measurement band of not less than 20mm wide shall be marked on the outboard end of the

boom. No part of the mainsail shall be aft of a line perpendicular to the top of the boom at the forward (inner) edge of the measurement band. See class rule 33.1.

28.5 The centre of the attachment of the clew of the mainsail shall not be more than 75mm above the top of the boom. No dimension of the clew ring shall exceed 150mm.

29 SPINNAKER POLE

The spinnaker pole shall be made of wood, aluminium alloy, GRP, Kevlar (TM) and/or carbon fibre reinforced plastic, or any combination thereof.

30 STANDING RIGGING

30.1 Standing rigging shall be made only of materials of specific tensile modulus not greater than  $2.9 \times 10^6$ m. (The specific tensile modulus is defined as the tensile modulus divided by the density.) Running backstays may be any material except carbon fibre.

30.2 The maximum cross sectional dimension of a headstay or headstay support device shall not exceed 75mm.

30.3 Adjustment of the topmast jumpers is prohibited whilst racing.

31 (SPARE NO.)

**SECTION F - SAILS**

32 SAILS - GENERAL

32.1 The yacht shall be rigged as a Bermudian sloop.

32.2 Except as otherwise prescribed in the class rule, sails shall be made and measured in accordance with the ISAF Equipment Rules of Sailing.

32.3 Non-woven and multi-ply sails are permitted provided the maximum initial fibre modulus does not exceed 1000 grams per denier. This limitation does not apply to fittings on the sail.

32.4 Reinforcement of a sail may be of any size provided it is flexible and capable of being folded without damaging the sail or the reinforcement and the fibre modulus limit above is not exceeded.

32.5 The following are specifically prohibited:

(a) double-luffed sails;

- (b) artificially thickened sails, eg., foamed sails;
- (c) double-surface inflatable sails, whether inflated by the action of the wind or not;
- (d) battens and headboards in headsails and spinnakers.

32.6 National letters and sail numbers are required to be carried on the mainsail only, altering racing rule 77 and Appendix H 1.1.

32.7 The following minimum sizes for national letters and sail numbers are prescribed, altering racing rule 77 and Appendix H 1.2:

Height	660m
Width	440mm*
Thickness	100mm
Space between adjoining letters/numbers	130mm

\*except the number 1 and the letter I

32.8 A headsail (genoa, staysail, spinnaker or gennaker) shall not have a club-foot or foot-yard, or have more than one sheet or any other contrivance for extending the sail to other than a triangular shape.

### 33 RATED SAIL AREA

33.1 Mainsail. The rated area of a triangular mainsail equals  $0.5 \times P \times E$ , where:

- (a) P equals the distance between the upper and lower measurement bands on the mast; and
- (b) E equals the maximum distance from the inner edge of the boom measurement band to the foreside of the luff groove in the mast.

33.2 Fore-Triangle. The rated area of the fore-triangle is  $0.5 \times 0.85 \times I \times J$ , where:

- (a) "I" is the height of the fore-triangle measured from the point 180mm above the sheerline in way of the forward side of the mast. "I" shall not exceed 18.750m.
- (b) The upper point of "I" shall be the highest of:
  - (i) the intersection of the line of the aft side of the forestay with the foreside of the mast;

- (ii) the intersection of the line of the forward side of the headfoil into which the luff of a headsail is fitted, with the foreside of the mast;
  - (iii) the bearing surface of a jib or spinnaker halyard sheave above which the sail cannot be hoisted;
  - (iv) the intersection of a line parallel to the forestay with the foreside of the mast through any contrivance which supports a jib or spinnaker halyard forward of the face of the mast.
- (c) "J" is the base of the fore-triangle measured from the foreside of the mast to whichever gives the greatest measurement:
- (i) the intersection of the line of the aft side of the forestay with the deck (line connecting the sheerlines);
  - (ii) the intersection of the line of the foreside of the headfoil with the deck (line connecting the sheerlines);
  - (iii) the outer edge of the spinnaker pole with the spinnaker pole in the position which gives the largest measurement.

#### 34 MAINSAIL

- 34.1 The distance between the aft side of the mast and the aftmost edge of the headboard and/or headboard carriage on the mast shall not exceed 362mm. If there is a luff groove in the mast, the measurement shall be taken to the fore-side of the groove.
- 34.2 The total width of the mainsail, including the luff tape, at half and three-quarter heights shall not exceed 68% and 41%, respectively, of the maximum permitted foot length "E". These measurements shall be taken from the half and three-quarter points on the leech to the nearest points on the luff. Hollows in the leech in way of the measurement points shall be bridged.
- 34.3 Not more than four batten pockets shall be fitted in the leech of the mainsail and shall divide the leech into approximately equal parts.

The length of battens is not limited. Note: For Division C yachts, Appendix E of this Class Rule places a limitation on batten length for the lower two battens

#### 35 GENOA AND STAYSAIL

- 35.1 Racing rule 50.4 shall not apply, but the maximum mid-width of any genoa or staysail, measured between the midpoints of the luff or leach, shall not exceed 60% of the length of the foot.

35.2 The maximum foot length of any genoa or staysail shall be  $(J + 4.8)$ m. When in use, a genoa or staysail shall be tacked on the hull such that the clew cannot extend more than 4.8m aft of the foreside of the mast.

### 36 SPINNAKER

36.1 A spinnaker shall be symmetrical about the line joining the head to the centre of the foot. The luff and leech shall be of equal length. The luff and leech shall be taped with stretch-resistant tape.

36.2 The lengths of the luff and the leech shall not exceed  $0.8(\sqrt{I^2 + J^2}) + 2.5$ m. (See class rule 33.2 for the definitions of I and J .)

36.3 The length of the foot, measured round the edge of the sail, shall not exceed  $2.5 \times J$  m.

36.4 The mid-width shall not be less than 75% of the length of the foot. The mid-width shall be taken as the distance between the midpoints of the luff and the leech measured as the shortest path on the surface of the sail.

36.5 Intentional openings in the sail, in addition to normal cringles and reefing eyelets, are permitted provided the sail is substantially flat in the vicinity of the openings.

### 37 GENNAKER

37.1 A gennaker is permitted provided the:

- (a) luff length shall not exceed  $\sqrt{I^2 + J^2}$ m;
- (b) leech length shall not exceed  $S(I^2 + 4.82)$ m;
- (c) foot length shall not exceed  $J + 4.8$ m.
- (d) mid-width shall not exceed 100% of the foot length measured between midpoints of the leech and luff.

37.2 The gennaker shall be set:

- (a) with the tack on the centreline of the hull in close proximity to the deck and no further forward than the forward limit of "J" ; or
- (b) as for a spinnaker in accordance with racing rule 50.

### 38 (SPARE NO.)

## **SECTION G - OTHER RULES**

### 39 RUNNING RIGGING, FITTINGS AND OTHER EQUIPMENT

- 39.1 Running rigging may be made of steel, nickel/cobalt alloy or rope of natural or synthetic materials such as Kevlar(TM) and Spectra(TM). Carbon fibre is not permitted.
- 39.2 Fittings may be made of any material except boron and ceramics.
- 39.3 While racing, a yacht shall carry on board the equipment listed in class rule 48.4. All equipment shall be bona fide of the nature common to the usual fittings of a yacht and shall not be of the nature of ballast.
- 39.4 Liquids and consumable stores including containers carried while racing shall not exceed 80kg.

### 40 CREW

Unless otherwise prescribed, there shall not be more than fourteen (14) persons on board while racing.

### 41 (SPARE NO.)

## **SECTION H - ADMINISTRATION**

### 42 APPLICABLE RULE, RULE COMPLIANCE AND OWNER'S RESPONSIBILITY

- 42.1 ("Grandfather Rule") Yachts shall be surveyed, measured and rated in accordance with, and otherwise comply with, the class rule and scantlings current when the yacht was first certificated, except that:
- (a) replacement spars and equipment shall comply with the class rule current at the time of replacement;
  - (b) sails shall comply with the current class rule; and
  - (c) a yacht which has had the shape of the underwater part of her hull excluding the keel altered, or the position of a rudder post altered, or freeboard altered, shall be measured for waterline length and freeboard under the class rule current at the time of alteration.
- 42.2 ("Gross Non-compliance Rule") Prior to presenting a yacht for survey or measurement, it is the owner's responsibility to assure that the yacht complies with these class rules. If in the opinion of the measurer a yacht presented is grossly out of compliance with the applicable rules,

he shall so report to the ITMA Technical Director and, if appropriate, the international jury. At a regatta, gross non-compliance in and of itself shall be grounds for action under racing rule 69.

- 42.3 The owner shall be responsible to permit and assist all inspections by surveyors, measurers and measurement committees, and shall afford all reasonable facility to carry out such inspections in regard to measurements, marks, fittings, construction and materials.
- 42.4 The owner shall be responsible to see that the yacht, its spars, sails and equipment comply with the class rule and racing rules at all times while racing, and that any alterations, replacements and repairs do not invalidate the measurement or survey certificates.

### 43 MEASUREMENT CERTIFICATE

- 43.1 The measurement certificate form, Appendix "A," shall be used by ITMA in issuing measurement certificates in accordance with the class rule.
- 43.2 To obtain a measurement certificate:
- (a) for a new yacht, the owner shall apply to his national authority for a sail number and shall pay the international class fee to ISAF;
  - (b) for all yachts, the owner shall have paid a current ITMA membership for the yacht;
  - (c) the owner shall arrange for a measurer approved in accordance with class rule 44 to measure and carry out a post construction inspection on the yacht in accordance with the class rule;
  - (d) following measurement and post construction inspection , the owner shall send the original rating and post construction inspection report certificates, completed, to the ITMA Technical Director;
  - (e) the ITMA Technical Director shall satisfy himself, so far as he can, that the yacht has been measured and inspected correctly and that the rating has been correctly calculated;
  - (f) when so satisfied, the ITMA Technical Director shall endorse the measurement certificate and return it to the owner;
- 43.3 The measurement certificate ceases to be valid:
- (a) two years after the date of issuance;

- (b) if there is any change in the yacht's displacement or trim, including alterations in the internal ballast;
- (c) if there is any change made to the hull or its appendages that may alter any of the measurements on the measurement certificate;
- (d) if any dimension of the rated sail area is increased;
- (e) if the position of the forestay is moved;
- (f) the position of the mast at any time reduces the J measurement by more than 200mm, or the pivot point of the mast is moved by more than 75mm;
- (g) any alteration is made which would cause the yacht not to comply with any requirements of the class rule, or measurement certificates.

43.4 In the case of class rule 43.3 (a) above, the certificate may be re-validated following a successful afloat test, and receipt of a declaration that no changes have been made which invalidate the measurement certificate or the survey certificate.

43.5 In the cases of class rule 43.3 (b), (c), (d) and (e) above, a new measurement certificate may be issued or the current certificate re-validated following partial or complete re-measurement or resurvey, as appropriate.

A yacht shall have only one valid "Grand Prix" measurement certificate at any one time. A "Grand Prix" certificate is defined as a certificate which certifies a yacht is in accordance with the main body of this Rule and does not have any Appendix E age allowance factor applied to the rating of the yacht. Yachts may have an "Appendix E" certificate in addition to a "Grand Prix" certificate provided the hull measurement and flotation remain unchanged between the certificates. Rig and spar dimensions may vary between certificates.

43.7 Copies of the front page of a yacht's measurement certificate shall be provided to anyone upon request by ITMA, which may charge a nominal administrative fee. A copy of a yacht's entire certificate shall be provided by the owner to the measurement committee. ITMA and measurement committees shall hold certificates in confidence.

#### 44 MEASURERS

Measurers qualified to carry out post construction inspections or measure yachts shall be appointed by ITMA Executive Committee upon the recommendation of the Technical Director and the Technical Committee.

A measurer shall not inspect for minimum weight distribution compliance or measure yachts, spars, sails and other equipment which he owns, designed or built, or in which he has a vested interest.

45 PLAN APPROVAL AND POST CONSTRUCTION INSPECTION

45.1 Before construction, four copies of the construction plans and weight distribution data shall be submitted to the ITMA Technical Director for assessment of the compliance with the minimum weight distribution requirements of the Rule.

45.2 These plans shall include:

- (a) shell expansion or body plan or girth table;
- (b) sections at each major or web frame sufficient to enable all items of structure to be identified and assessed;
- (c) longitudinal construction profile and deck plan including cockpits and hatches.

45.3 The plans shall be to scale and shall accurately depict the shape of the yacht so that surface areas can be checked.

45.4 The construction plans shall show information for each of the allowable materials, for example:

- (a) aluminium or steel alloys--minimum thickness of plating and sizes of all structural members; alloy description and density.
- (b) GRP--full details of laminates including type of glass, type of material or cloth and the weight and thickness of each layer; total thickness of skins (inner and outer as required); thickness of framing encapsulation; resin type and density (generic and brand names); core types and densities (generic and brand names); designed glass content in each area; details of any non-GRP structural components.
- (c) wood--species and their nominal minimum densities; thickness of skins/planking; dimensions of framing and stiffening members; fastening specification including glue (for weight analysis); details of non-timber structural components.

All but two copies of the plans and information provided by the owner as part of the weight distribution assessment process shall be returned to the owner with the remaining copies being held by the ITMA Technical Director.

- 45.6 The ITMA Technical Director shall hold submitted plans in confidence, with a copy made available only to the measurer appointed to carry out post construction inspection in accordance with class rule 45.
- 45.7 It shall be the owner's responsibility to see that the yacht is constructed in accordance with the approved plans and the weight distribution requirements in class rule 18.
- 45.8 For a GRP yacht:
- (a) to assist the measurer carrying out the post-construction survey, it is recommended that the builder of a GRP hull keep, detailed records of all materials and their positions in the hull.
  - (b) the builder shall lay up test panels using the same techniques, sequences and reinforcement as are used in the actual laminates for all major areas of the yacht; these test panels shall be made available to the measurer for inspection and calibration of electronic measurement equipment.
- 45.9 Following construction but prior to fairing and painting, a post construction inspection shall be carried out by the measurer to ensure the hull has been built in accordance with the minimum weight distribution requirement of the Rule.
- 45.10 The measurer shall determine if the girths for the calculation of areas provided in the submitted body plan or shell expansion drawing or girth table agree with the girths at each section on the yacht as built;
- 45.11 The measurer shall determine if the yacht is built in accordance with, or in excess of, that required in the plans approved by the ITMA Technical Director and unless otherwise specified by the ITMA Technical Committee, this post construction inspection shall consist of the following:
- (a) macro examination of the yacht plating, skin laminate or planking and supporting structure using appropriate devices which may include normal measuring instruments, ultrasonic and other electronic equipment as the measurer and the ITMA Technical Director see fit;
  - (b) thickness measuring of plating and structure by the drilling of three pilot holes of approximately 5mm in diameter in each of the bottom, topsides and deck regions of each of the three longitudinal hull zones as defined in class rule 18.3 for a total of 27 pilot holes;
  - (c) at each pilot hole the thickness of plating, laminate (inner and outer skin as required) or planking at each hole shall be measured;

- (d) the dimensions of stiffeners (and encapsulation) shall be measured;
- (e) for aluminum alloy construction, alternative means of determining thickness may be used with the written consent of the ITMA Technical Director;
- (f) for GRP and wood yachts, in addition to the above, a minimum of two samples of approximately 50mm diameter shall be taken from each longitudinal region of the yacht; these samples, which may be machined to round, shall be weighed to establish compliance with the approved weight distribution requirements;
- (g) the number and position of pilot holes and core samples over and above those required in the preceding shall be at the discretion of the measurer , or if in dispute with the owner, of the ITMA Technical Director.

45.12 The measurer shall indelibly mark the position of all holes after repair. This indelible mark, which shall be visible at all times, shall be:

- (a) for an aluminium yacht, a metal stamp/seal punched on the inside of the plating in the vicinity of the sample position;
- (b) for a GRP or wooden yacht, a signed identification card which is glassed to the inside of the yacht in the vicinity of the sample positions.

45.13 Removal of or interference with these identification marks will invalidate the yacht's measurement certificate.

45.14 The measurer may also require a still and/or video photographic record to be taken of the inside of the hull upon completion of the survey.

45.15 The measurer may also require the designed hull weight, excluding fittings, to be verified by weighing.

45.16 Upon satisfactory completion of the post-construction inspection, a certificate will be issued by the ITMA Technical Director. This certificate will be required to be produced at all ITMA sanctioned regattas.

45.17 The notice of race may require that, as a condition of entry, yachts be fully resurveyed prior to the regatta to assure continuing compliance with the class rule.

46 MEASUREMENT - GENERAL

- 46.1 Measurement shall be taken in accordance with the "ISAF Equipment Rules of Sailing" unless otherwise prescribed.
- 46.2 A measurer shall not take any measurement other than those necessary for determining the yacht's rating and its compliance with the class rule, except as directed by the ITMA Technical Director.
- 46.3 Unless otherwise prescribed, all measurements shall be taken without crew on board.
- 46.4 At the time of measurement ashore and afloat, backstays, runners and forestays shall be slack.
- 46.5 Calculations shall be rounded to the nearest millimetre, or to the third place of decimals for measurements of area or volume.

A yacht may be remeasured at the discretion of ITMA or the measurement committee.

47 MEASUREMENT MARKS (See also Appendix "B")

- 47.1 Measurement marks shall be painted or fastened to the hull at the measurement points as shown in Appendix "B".
- 47.2 The marks shall be clearly discernible and of a colour different from the hull. The measured points shall be marked by a cross head screw or indentation on the surface of the hull.
- 47.3 The mid-ship section LWL triangular measurement marks shall have a vertical distance between the top and the lower corner not exceeding 50mm.

48 MEASUREMENT AFLOAT

- 48.1 For the measurement afloat, the mast shall be vertical.
- 48.2 The measured displacement for class rule 12.1 shall be determined for seawater of specific gravity of 1.025 based on the weight of the yacht. For minor differences of specific gravity, the measurer shall allow 0.7mm sinkage for 0.001 reduction in specific gravity, measured at the time of measurement afloat.
- 48.3 Subject to class rule 6.7, the measurer shall check that the waterline length marks "L" are not within the length immersed, and that the lower corners of the "I" marks just touch the water.
- 48.4 When the yacht is measured afloat, the following items shall be onboard and in their normal fore and aft position of use (the anchor,

chain and rope shall be located within 3.0m of the centre of gravity as determined by the lifting eyes and carried there while racing; this location shall be noted on the certificate) and other equipment may be removed:

- (a) spars and associated standing rigging, including spinnaker pole;
- (b) normal halyards, running backstays and one set of sheets for mainsail, genoa and spinnaker, together with associated turning blocks;
- (c) one mainsail, one genoa and one spinnaker;
- (d) one anchor of high holding power and weighing not less than 18kg, with not less than 10.0m of 10mm short link steel chain shackled to the anchor;
- (e) not less than 90m of 16mm minimum diameter nylon or dacron rope;
- (f) all winches, including drive units, pedestals and cranks, together with not less than two handles total for deck winches;
- (g) hatch covers as specified in class rule 23;
- (h) not less than two fixed bilge pumps, operable from the deck, with a total capacity of not less than 200 litres per minute, and fitted with a fixed overboard, or onto the deck, pump discharge; Additionally electric bilge pumps are permitted.
- (i) floorboards as normally used;
- (j) all batteries (their position shall be noted on the certificate, and they shall be in that position while racing);
- (k) personal buoyancy, one per crew member;
- (l) running lights; and
- (m) a horseshoe type lifebuoy, fitted with a whistle and a colour dye marker, kept on deck within reach of the crew.

48.5 The tops of the triangular side marks "I" shall not be immersed when the yacht is in level trim, with equipment specified in class rule 48.4 plus the following on board in normal fore and aft racing position:

- (a) 11 crew;
- (b) sails; and

- (c) all additional equipment carried while racing not otherwise specified in class rule 48.4.
- 48.6 The measurer may check compliance with class rule 48.5 at any time, provided that:
- (a) reasonable time shall be allowed to dry out the yacht and equipment; and
  - (b) when suitable certified weighing equipment is available by weighing, in which case the weight of the yacht in the condition described in 48.5 shall not exceed the measurement weight by more than the weight in kilograms given by the formula:  $130 \times \text{LWL}$  (in metres).



# INTERNATIONAL TWELVE METRE CLASS 12

## MEASUREMENT CERTIFICATE

Yacht's Name		National letters and Sail Number	
Designer	Builder	Year built	
Owner		Club	
Owner's Address			

Classification certificate (Number or Date)

This certificate is dated _____	<b>and its validity confirmed by</b>
Owner's Signature: _____	
Valid until _____	(Class Technical Director)
Supersedes _____	(enter former certif. number or date)

### RATING CALCULATIONS

<b>OVERALL LENGTH</b>					
Overhang Forward to L1					
Overhang Aft to L1					
Total Overhang (Subtract)					
<b>MEASURED LENGTH (L1 L1)</b>					
Girth at Bow					
Twice vertical Height at Bow (Subtract)					
O at Bow					
Add 1 1/2 O at Bow (min 0.540 m)					
Girth at Stern					
Twice vertical Height at Stern (Subtract)					
O at Stern					
Add 1/3 O at Stern (min 0.400 m)					
Add any penalty (Displ.)					
<b>CORRECT LENGTH L</b>					
Skin d to d1 Port					
Chain d to d1 Port					
d Port					
Skin d to d1 Starboard					
Chain d to d1 Starboard					
d Starboard					
Add d					
<b>Add GIRTH 2 d</b>					
Mean Freeboard Bow O	Actual				
Mean Freeboard Midship d	Actual				
Mean Freeboard Stern O	Actual				
Sum of Freeboards					
<b>Subtract FREEBOARD, F</b>					
<b>Add SAIL AREAS (Square root)</b>					
<b>TOTAL OF MEASUREMENTS</b>					
PENALTY (Draught)					
<b>RATING</b>					

**INTERNATIONAL TWELVE METRE CLASS RULE 2011**

**PENALTIES**

Internal Ballast	Weight	Loc. from bow		
Overhang Forward to L			<input type="text"/>	
Overhang Aft to L			<input type="text"/>	
Subtract from overall length			<input type="text"/>	
Difference of immersion from salt to fresh water			<input type="text"/>	
<b>WATERLINE LENGTH</b>				
Minimum Displacement for Zero Penalty [m <sup>3</sup> ]			<input type="text"/>	<input type="text"/>
Minimum Weight for Zero Penalty [tonnes] (Water of sg 1.025)			<input type="text"/>	
<b>DISPLACEMENT (by weighing)</b>				
Equivalent LWL (for Displ. < min.)			<input type="text"/>	
Difference			<input type="text"/>	
DISPLACEMENT PENALTY (add to L)				<input type="text"/>
<b>DRAUGHT (actual)</b>				
Max. Draught for Zero Penalty			<input type="text"/>	
Difference (if positive)			<input type="text"/>	
DRAUGHT PENALTY (add to Rating)				<input type="text"/>
<b>BEAM (Min)</b>				
Max Beam at 1/3 of Midship Freeboard			<input type="text"/>	
Difference (if positive)			<input type="text"/>	
BEAM PENALTY (add to L)				<input type="text"/>
Tumblehome Max. (2 x 2% of Extr. Beam)			<input type="text"/>	
Extreme Beam			<input type="text"/>	
Beam at deck			<input type="text"/>	
Difference (if positive)			<input type="text"/>	
TUMBLEHOME PENALTY (add to Rating)				<input type="text"/>

**SAIL PLAN**

Max Height of Sail Plan = <input type="text"/>	<b>J=</b>	<input type="text"/>	<b>I =</b>	<input type="text"/>
	<b>Spi pole =</b>	<input type="text"/>		
Boom Height = <input type="text"/>	<b>A=</b>	<input type="text"/>	<b>B=</b>	<input type="text"/>
Rated Mainsail Area	<input type="text"/>			
Rated Foretriangle Area	<input type="text"/>			
TOTAL RATED SAIL AREA		<b>S=</b>	<input type="text"/>	

**SAIL LIMITS**

Mainsail:	max girth at 1/2 height (68%)	<input type="text"/>
	max girth at 3/4 height (41%)	<input type="text"/>
Genoa:	max. foot length (J + 4.8m)	<input type="text"/>
Spinnaker:	max. luff length	<input type="text"/>
	1/2 foot max width (125% J)	<input type="text"/>

**SPARS MEASUREMENTS**

MAST (material)	<input type="text"/>	Mast Weight	<input type="text"/>	Mast CG position (from meas. point)
	Deck	Half-Height	Jib-Halyard	Head
Mast dimensions	<input type="text"/>	<input type="text"/>	<input type="text"/>	<input type="text"/>

**PROPELLER INSTALLATION**

	Yes/No	
Date and place of Measurement	Measurer's Name(s)	
Measurer's signature	Technical Director approval	

**HULL SURVEY**

Classification Society Plan Approval No: ..... Date:.....  
 Survey Number: ..... Date:.....  
 Supersedes Survey No: ..... Date:.....  
 Construction Material:.....  
 Construction Documentation:.....  
 Test Samples: .....  
 Density Check: .....  
 Test Methods: .....

**PILOT HOLE THICKNESS SURVEY**

Position No	Outer Skin	Cora	Inner Skin
Bottom Fwd Approved Plan			
Actual No 1			
Actual No 2			
Actual No 3			
Bottom Mid Approved Plan			
Actual No 1			
Actual No 2			
Actual No 3			
Bottom Aft Approved Plan			
Actual No 1			
Actual No 2			
Actual No 3			
Topside Fwd Approved Plan			
Actual No 1			
Actual No 2			
Actual No 3			
Topside Mid Approved Plan			
Actual No 1			
Actual No 2			
Mast Approved Plan			
Actual No 3			
Topside Aft Approved Plan			
Actual No 1			
Actual No 2			
Actual No 3			

INTERNATIONAL TWELVE METRE CLASS RULE 2011

Deck Forward Approved Plan			
Actual No 1			
Actual No 2			
Actual No 3			
Deck Mid Approved Plan			
Actual No 1			
Actual No 2			
Mast Approved Plan			
Actual No 3			
Deck Aft Approved Plan			
Actual No 1			
Actual No 2			
Actual No 3			

**Framing Survey**

<b>Position No</b>	<b>Web</b>	<b>Flange</b>	<b>Scantling</b>
Bottom Fwd Approved Plan			
Actual			
Bottom Mid Approved Plan			
Actual			
Bottom Aft Approved Plan			
Actual			
Topside Fwd Approved Plan			
Actual			
Topside Mid Approved Plan			
Actual			
Topside Aft Approved Plan			
Actual			
Deck Fwd Approved Plan			
Actual			
Deck Mid Approved Plan			
Actual			
Deck Aft Approved Plan			
Actual			

No	Position	Diameter	Weight	Weight/Area	Reqd Weight/Area
1 Fwd					
2 Fwd					
1 Mid					
2 Mid					
1 Aft					
2 Aft					
Other					

**Sketch Showing Position of Pilot Holes and Core Sample Positions**

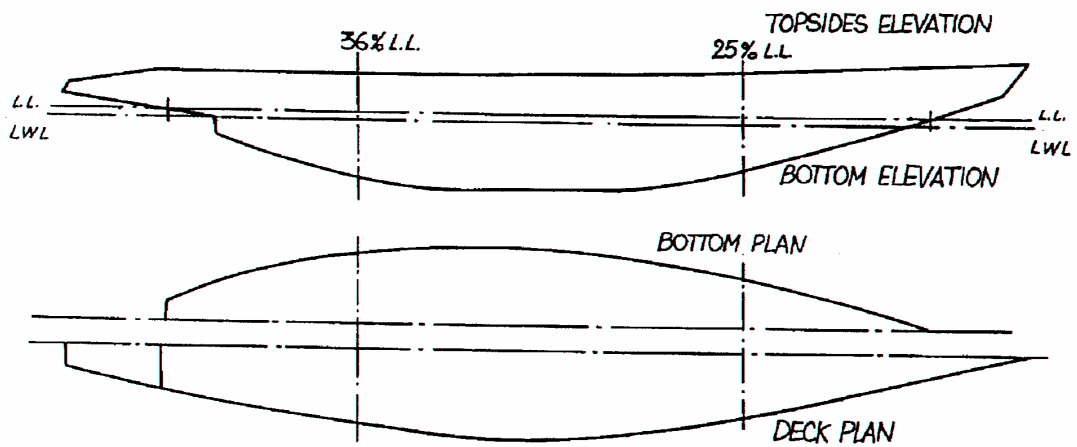

Appendix B - Measurement Marks

The following marks shall be placed on the hull:

No Required	Description
2	Upper length marks, L1
2	Lower length marks, L
2	Upper d marks, d
2	Immersion marks, 1
2	Lower d marks, d1
4	Overhang girth marks, 0
1	Outer after length mark, L2
2	Outer overhang girth marks, 02

**Position**

Ends of measured length  
 Ends of LWL  
 Sheerline at mid-ship girth station at 0.55 LWL  
 LWL at mid-ship girth station  
 Sides of vessel 1.500m below LWL at mid-ship stn,  
 Ends of measured length  
 As prescribed in rule 2.2  
 Vertically above the outer length mark, L2

The length marks, L, L1 and L2, shall be rectangular marks not less than 12mm in width and 150mm in length.

The immersion mark 1 shall be a triangular mark, thus:

The other marks shall be round marks of 20mm diameter.

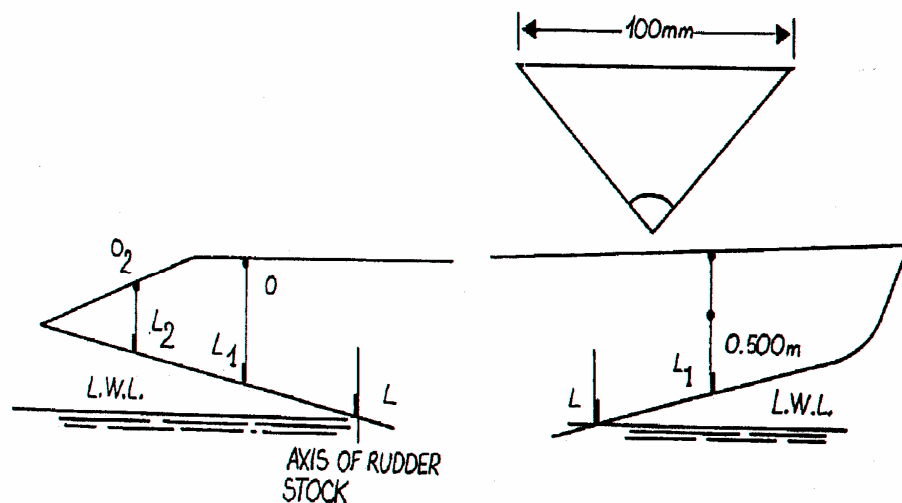

## Appendix B - Measurement Marks

<b>The marks shall be placed as follows:</b>
--

- a) The waterline marks, L, at the ends of the waterline. They shall be in the transverse plan, at right angles to the waterline, so that the inner edges of the marks denote the waterline ending (see diagram above) and as close to the centreline of the yacht as possible.
- b) The upper length marks, L1 on the fore part of the stem and the upper length marks L1 and L2 on the aft part of the counter. They shall be in the transverse plane at right angles to the centreline (see diagram) and as close to the centreline of the yacht as possible

The marks shall be fixed so that their inner edges are at the following heights above the waterline as follows:

Vertical height of mark L1 above LWL – 180mm

Vertical height of mark L2 above LWL – 360mm

- c) Overhang girth marks 0 at bow shall be fixed so that their centres shall be vertically above the outer edge of the L1 mark:

Vertical height of bow 0 mark above L1 – 600mm.

- d) Overhang girth marks 0 and outer overhang girth marks 02 at stern close below the sheerline, one on each side of the yacht, centres to be vertically above the outer edges of the L1 and L2 marks respectively (see diagram).

- e) Upper d marks d on the edge of or close below the sheerline, one on each side of the yacht at the mid-ship girth station.

- f) Immersion marks 1 on both sides of the yacht shall be vertically below the marks d with the bottom corners just touching the waterline.

- g) Lower d marks d1, one on each side of the yacht at the point vertically below the centre of the marks d and 1, so that the three marks shall be situated in the same transverse plane and shall be vertical to the LWL. The marks d shall be fixed at a vertical distance of 1500mm below the LWL.

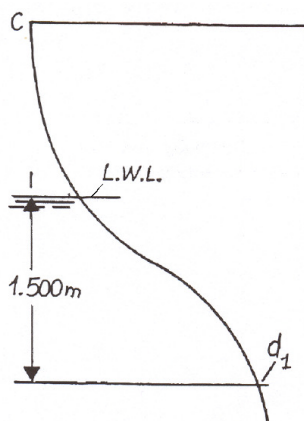

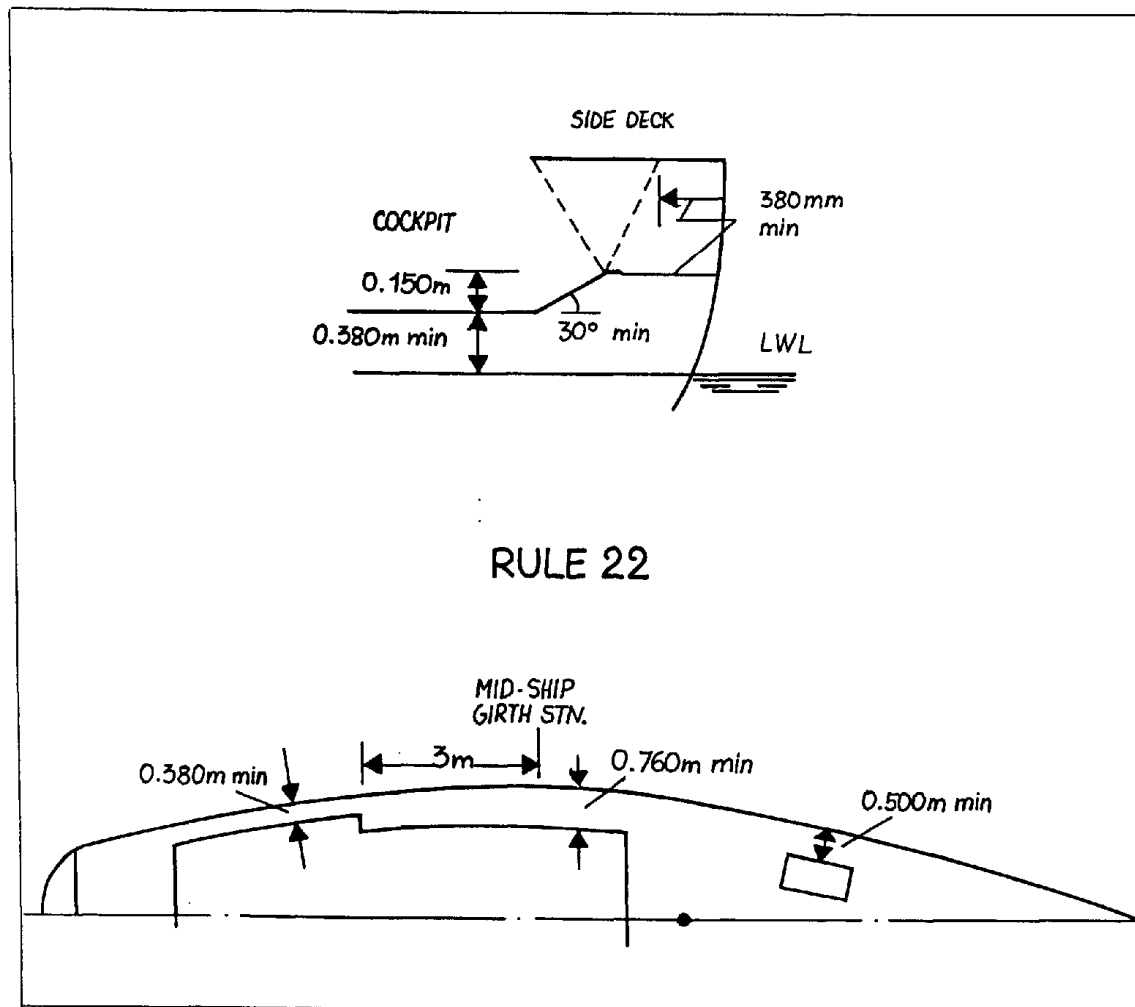
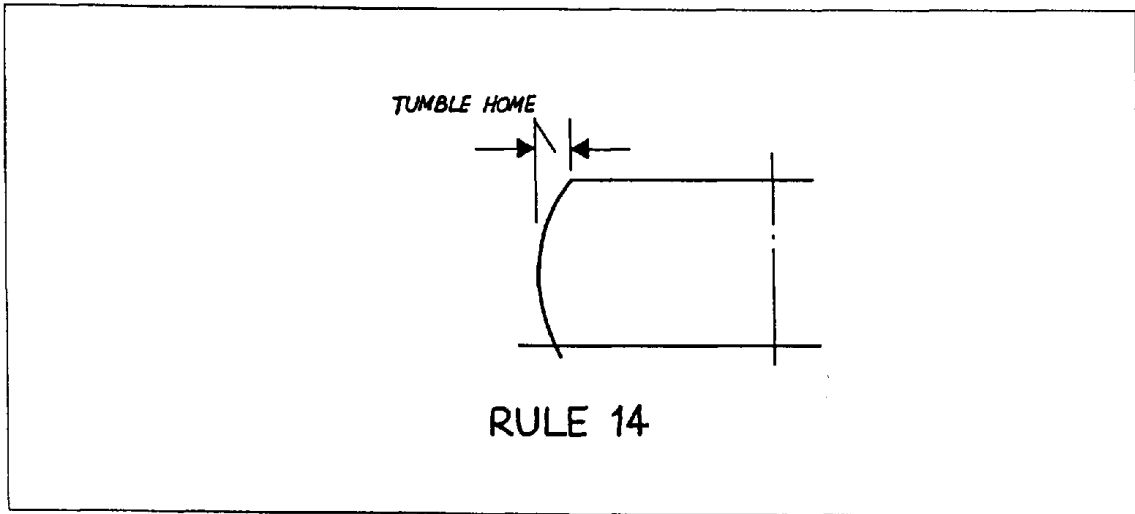

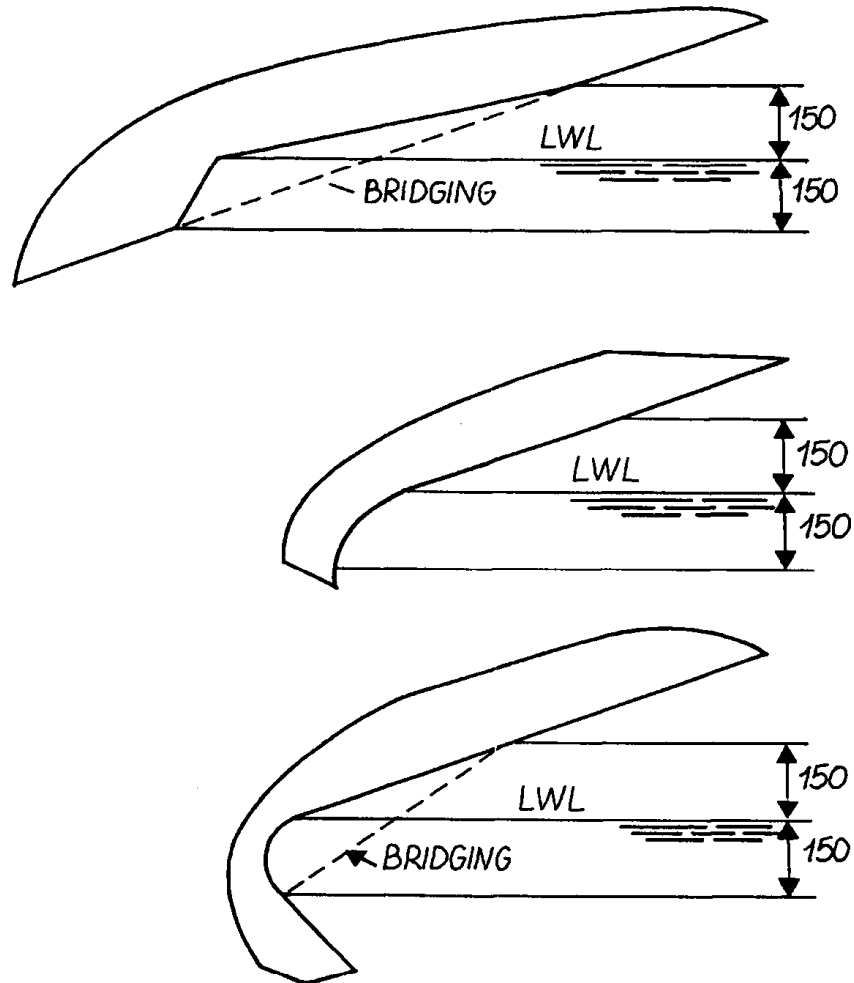

STEM PROFILE NEAR LWL

**Appendix E****Preamble**

This appendix has been developed to encourage racing between Twelve Metre Class Yachts of different eras which may not desire or be able to meet the strict flotation and compliance requirements of the “state of the art” Twelve Metre Class Rule.

**Fleet Age Division**

The development of the Twelve Metre Class is categorised into three distinct divisions as follows:

Period A	Wing Keel	Yachts with wing keels and/or constructed after 1983 (All 12's after 1983 but including Australia II (KA 6))
Period B	Modern Skeg-Rudder	Yachts without wing keels but with rudders separated from the keel. This corresponds to a period of 1968 to 1983. It includes Intrepid (US 22) and all yachts built after Intrepid but before Australia II (KA 6) but does not include Australia II.
Division C	Keel Hung Rudder (Traditional)	Sloops built in 1967 and before with keel hung rudders (except Intrepid (US 22))
Division D	Keel Hung Rudder (Vintage)	Yachts built before 1950 fitted with wooden spars unless originally fitted with aluminium spars
Division E	Keel Hung Rudder (Antique)	Gaff-headed and Bermuda rigged yachts built under the First Rule

**Age Correction to Length**

In order to partially account for design development with time and the normal increase in yacht displacement, compensation correction factors are applied to the “L” in the formula in Rule 5. This correction factor is given in Table 2.

Historically it is found that the displacement of Twelve Metre Class yachts increase with time. This may be due to a number of factors including uptake of water into the planking, additional accommodation, additional equipment including engines and propellers, and additional safety equipment.

This increase in displacement results in the fact that the yacht is unable to float on her original measurement waterline without the removal of ballast. If the Twelve Metre Rule were applied without correction the yacht would suffer

in rating. The yacht would have a longer L and would probably have a draft penalty and a displacement penalty.

Combined, these factors would result in a significant loss of rated sail area if the yacht were to rate 12.000 metres.

If the displacement gain were offset by the removal of ballast from the yacht to enable her to float at the desired measurement waterline the yacht would suffer a significant loss in her ability to carry sail.

With these facts in mind the ITMA Technical Committee set out to achieve some method by which existing, older style Twelve Metre Class yachts could be permitted to increase displacement (up to a limit) but not lose sail area and still remain a Twelve Metre Class Yacht. As yachts rated by this method will not strictly comply with the "Grand Prix" Rule, they will be issued with an "Appendix E" Certificate. This Certificate would enable the yacht to compete in ITMA-endorsed regattas as a Twelve Metre Class Yacht but not be eligible to win the World Championship or similar championships.

A length correction factor shall be applied to "L" in the Rating Formula in Rule 5. This factor is a function of the age of the yacht and the division into which the yacht falls. These divisions are defined above and are broadly age-based but are more specifically based upon underbody shape. This factor incorporates an element for sinkage from the original measurement waterline that varies with age as well as form factor.

Where this Appendix E is used, no draft or displacement penalty is incurred as a result of sinkage. However this dispensation shall not be optimised in any way. The depth of keel below a fixed hull datum shall not be increased from the yacht's original depth. For example, if the yacht had a draft penalty when first measured that draft penalty shall still apply.

The overall result of this approach is that an older yacht may float deeper than her original measurement waterline but may still be rated as a Twelve Metre Class yacht while retaining a similar sail area to that with which she was first measured.

The following table sets out the changes and notes related to each rule in the main part of the Class Rule.

**TABLE 1****Table of Relaxation's From Class Rule**

<b>Rule</b>	<b>Subject</b>	<b>Alteration and Notes</b>
1	Language	No Change
2	Interpretation	No Change
3	Amendments	No Change
4		
5	Rating	Length "L" corrected by Age/Keel Type Factor
6	Length	No Change. To be measured using method applicable at the time of original build but at existing current flotation waterline in measurement condition laid down in Rule 48 Yacht should be measured ashore by "flotation range" method.
7	Midship Girth Difference	No Change. To be measured using method applicable at the time of original build. To be recorded as the actual girth difference at current flotation waterline. Yacht should be measured ashore by "flotation range" method.
8	Freeboard	No Change. To be measured using method applicable at the time of original build but at existing current flotation waterline in measurement condition laid down in Rule 48 Yacht should be measured ashore by "flotation range" method.
9	Sail Area	No change but corrected with propeller allowance from Rule 10
10	Propeller Allowance	No Change
11	Draft	No penalty applicable for "natural" age sinkage draft increase.

INTERNATIONAL TWELVE METRE CLASS RULE 2011

Rule	Subject	Alteration and Notes
12	Displacement	No penalty applicable for insufficient displacement for existing current increased waterline length which results from “natural” age sinkage draft increase. If the yacht originally had a displacement penalty she shall continue to carry the same displacement penalty. “Natural” age sinkage includes the addition of accommodation, engines, tanks, batteries, etc. However these and similar items shall be of size and weight consistent with equipment fitted to racing yachts of similar size.
13	Beam	The minimum beam requirements shall only apply to yachts built after the minimum beam requirements were in effect.
14	Tumblehome	No Change
15	Sheer and Sheerline	No Change
16	Hollows	No Change
17		
18	Construction	Original Lloyd’s Class R certificate when the yacht was built is regarded as complying with the construction rules. Current Lloyd’s certificate is not required. Repairs and alterations must be of a standard consistent with original structure of yacht. The weight and weight distribution of any repair or alteration shall not be more favorable than the original construction of the yacht. Specific approval for alterations which are not similar to the original construction method or materials shall be sought from the Technical Director. In reviewing submissions seeking approval of alterations the Technical Director may request any calculations and drawings he may deem necessary.
19	Appendages	No Change
20	Keel and Other Ballast	No Change

INTERNATIONAL TWELVE METRE CLASS RULE 2011

<b>Rule</b>	<b>Subject</b>	<b>Alteration and Notes</b>
21	Deck	As per Rule when yacht was originally built
22	Cockpits	If applicable to be as per Rule when yacht was originally built, or as per Rule 23.7
23	Hatches and Companionways	If applicable to be as per Rule when yacht was originally built, or as per Rule 23.7
24	Minor Openings	If applicable to be as per Rule when yacht was originally built, or as per Rule 23.7.
25	Winch Placement	If applicable to be as per Rule when yacht was originally built.
26		
27	Mast	No Change except if original mast is still fitted the Rules at that time are to be used, and the mast cannot be moved at the deck level while racing.
28	Boom	No Change except if original boom is still fitted the Rules at that time are to be used
29	Spinnaker Pole	No Change
30	Standing Rigging	No Change
31		

INTERNATIONAL TWELVE METRE CLASS RULE 2011

32	Sails	<p>National Letters and Sail Numbers</p> <p>Sail Materials</p>	<p>Sail numbers and National letters as original are encouraged</p> <p>Division A yachts : No Change Division B yachts : No Change</p> <p>Division C yachts: Sail to be woven (non-laminated) with maximum fibre modulus of mainsails and Genoa's of not more than 120 grams/denier.</p> <p>Division D yachts: Sail to be woven (non-laminated) with maximum fibre modulus of mainsails and Genoa's of not more than 120 grams/denier</p> <p>or</p> <p>laminated polyester sails with a maximum fibre modulus of not more than 250 grams/denier certification marked for Division D yacht prior to 1 January 2008.</p> <p>Division E yachts: Sail to be woven (non-laminated) with maximum fibre modulus of mainsails and Genoa's of not more than 120 grams/denier.</p>
33	Rated Sail Area	No Change	
34	Mainsail	Rule 34.3 is altered for Division C yachts. The length of the lower two battens shall not exceed 2.5 metres.	
35	Genoa and Staysail	No Change	

**INTERNATIONAL TWELVE METRE CLASS RULE 2011**

<b>Rule</b>	<b>Subject</b>	<b>Alteration and Notes</b>	
36	Spinnaker	No Change	
37	Gennaker	No change	
38			
39	Running Rigging, Fittings and Other Equipment	No Change	
40	Crew	Division A Division B & C	14 16
41			
42	Applicable Rule, Rule Compliance Owner's Responsibility	No Change	
43	Measurement Certificate	Certificate Endorsed "Appendix E Certificate" where this appendix is used	
44	Measurers	No Change	
45	Plan Approval and Post Construction Inspection	Not required	
46	Measurement General	No Change	
47	Measurement Marks	No Change See Flotation Range Measurement Instructions	
48	Measurement Afloat	No Change	

**TABLE 2****Age Correction Factor Table**

Division	Period and Notes	Actual Year Built	Age Correction Factor (ACF)
A	Yachts built after 1983 but including Australia II (KA 6) All wing keel yachts	After 1983	1.00
B	Yachts built after 1967 but including Intrepid (US 22) until 1983 except Australia II Yachts with rudder hung aft and separately from the keel	1983	0.99
		Intermediate years by linear interpolation to 3 decimal places  1968	0.98
C,D and E	Yachts built in 1967 and earlier except Intrepid. Yachts with rudder hung from the aft end of the keel.	1967	0.97
		1950	0.96
		1939-1950	0.96
		1939	0.96
		1920	0.95
		1907 Bermuda Rig	0.93
		1907 Gaff Rigged	0.92
		Intermediate years by linear interpolation to 4 decimal places	
		If a yacht was fitted with a wooden mast when first measured and she is now fitted with an aluminium mast, 0.004 shall be added to her ACF	

This age correction factor (ACF) shall be applied using the most recent date of when the yacht was built or first measured and issued with a measurement certificate.

If the yacht has been modified since she was built or first measured and issued with a measurement certificate the following factors shall be taken into account in determining the appropriate ACF.

If the canoe body excluding the appendages or shape of the external ballast has been modified the impact on the ACF shall be 50% as determined in the table below. A hull modification shall be deemed to have taken place when the total canoe body surface area below the L1L1 plane is changed by 20% or greater from the original canoe body shape.

If the shape of the ballast keel or its appendages has been modified the impact on the ACF shall be 50% as determined in the table below.

In the case of alteration the component alteration ACF shall be that which applies at the time of alteration. However, if the alteration was carried out outside the age range in table 2 the alteration shall be considered as occurring at the most recent limit of the age range, provided the alteration maintains the characteristic style of the age range.

That is, if a new keel (appendage) was added to a 1950 yacht in 1999, the ACF factor to be used for the keel (appendage) alteration shall be that which would apply as if the keel alteration was undertaken in 1967.

This methodology is explained using the following example.

A yacht was built or first measured and issued with a measurement certificate in 1970 making her base ACF = 0.982

Her appendages and shape of external ballast were modified in 1974

Her hull was modified more than the 20% of the canoe body area under the L1L1 plane in 1977.

<b>Alteration</b>	<b>Alteration Date</b>	<b>Component Alteration ACF</b>	<b>ACF Component Calculation</b>
Original Certificate	1970		Base ACF = 0.982
Appendage/ Shape of External Ballast Change	1974	0.984	$(0.984 - 0.982)/2 = 0.001$
Hull altered	1977	0.986	$(0.986 - 0.982)/2 = 0.002$
ACF			$0.982 + 0.001 + 0.002 = 0.985$